



# Extrusion Tips and Dies

## Cabling Tools

www.estevesgroup.com



### Highlights

- Wire perfectly centered
- Insulation material savings
- Optimal insulation flow
- Various materials available

**Superior tool concentricity allows wire insulators to meet the demands of today's super thin-wall constructions.**

Extrusion tools are commonly used to apply an insulating layer around a solid or stranded wire. The extrusion tip, also called extrusion wire guide, guides a single or group of wires into and through an extrusion die. The extrusion die controls the shape and size of the insulating material around the wire.

State-of-the-art technology and tight concentricity (0.005 mm / .0002") of **Esteves Group** extrusion tools give the insulator the ability to maintain uniform insulation thickness minimizing material usage and scrap.

Super-hard material inserts in the wire guides, primarily diamond and carbide, ensure long tool life even at high extrusion process speeds. Esteves Group extrusion tools are manufactured with a mirror polish and no sharp edges to ensure optimal insulation material flow and easy threading.

**Virtually any extrusion tooling shape for any type of crosshead is available from Esteves Group.**

### We Specialize in...

- Wire Drawing Dies
- Bunching, Stranding & Compacting Dies
- Split Dies
- Tubing Dies
- Shaped Dies
- Extrusion Tooling
- Die Reconditioning Tools
- Engineering Services
- Customer Support

More **throughput**, **less material** usage, **less scrap**, and **higher quality** all add up to more profit for the insulated wire and cable manufacturer.

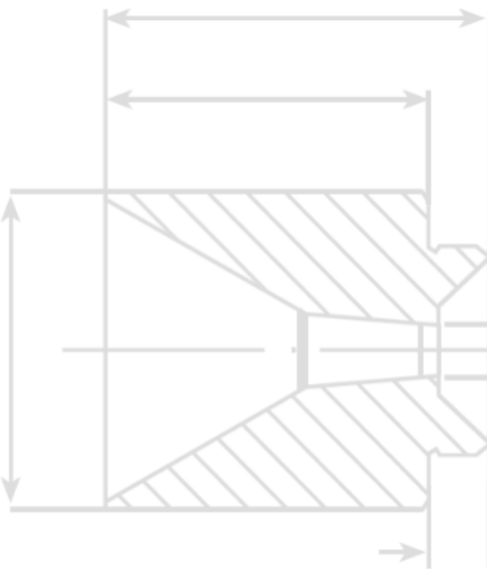
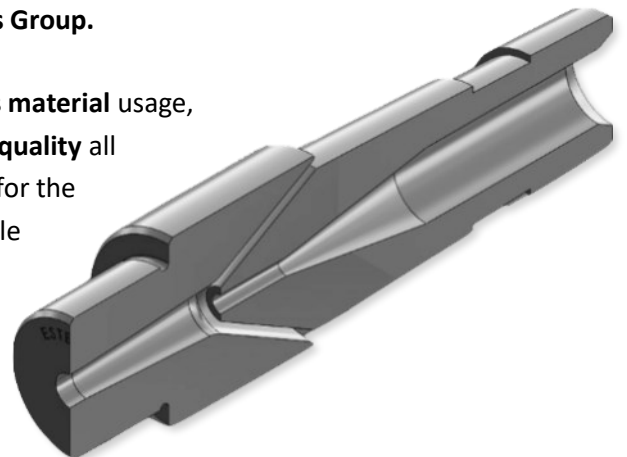

### Key Features

- Very high tip concentricity
- Very high tip roundness
- Inserts located close to tip's end
- Various materials available
- High surface finish

### Benefits

- Insulation material savings
- Even insulation thickness all around
- Wire perfectly centered within insulation material
- Optimal insulation flow
- Long lasting tools

Extrusion tip (extrusion wire guide) specifications	Product name	Diamond insert tip	Tungsten carbide insert tip	Solid tungsten carbide tip	Solid steel tip
	Size range <sup>1)</sup>	0.25 - 4.00 mm [.0098 - .1575"]	0.7 - 5.0 mm [.0276 - .197"]	1.20 - 8.0 mm [.047 - .315"]	1.0 -125 mm [.039 - 4.921"]
	Insert material	Diamond (PCD, SSCD, ND)	Tungsten Carbide (TC)	Solid Tungsten Carbide (TC)	Solid Steel
	Body material	Steel			
	Distance to product tip <sup>2)</sup>	≥ 0.6 mm [≥ .0236"]	0 mm [0"]		
	Concentricity	± 0.005 mm [.000197"]			

Extrusion die specifications	Product name	Solid tungsten carbide die	Tungsten carbide insert die	Ceramic insert die	Solid steel die
	Size range <sup>1)</sup>	0.8 - 8.0 mm [.031 - .315"]	0.8 - 8.0 mm [.031 - .315"]	≥ 2.0 mm [≥ .0787"]	8.0 -35 mm [.315 - 1.38"]
	Insert material	Solid Tungsten Carbide (TC)	Tungsten Carbide (TC)	Ceramic	Solid Steel
	Body material		Steel	Steel	
	Concentricity	± 0.005 mm [.000197"]			

<sup>1)</sup> Other sizes are available on request

<sup>2)</sup> Insert materials are located as close as possible to the tip's end to ensure perfect guiding of the wire.

Virtually any extrusion tooling shape for any type of crosshead is available.  
Please contact **Esteves Group** for a quotation for your extrusion tooling.

Extrusion tooling examples below:

single conductor compression tip,  
two conductor semi compression tip, fixed center tooling

